

On-Premises 30-lb Tumble Dryer



Our single-pocket tumble dryers* feature concentrated airflow and sealed cylinder rims to ensure energy savings. This superior drying performance helps laundries maximize throughput to meet the daily workload every time. Our tumble dryers are designed with fewer moving parts, so you'll face less maintenance and wear and tear.

Efficient

High-performance heater box increases energy efficiency and reduces drying times to help on-premises laundries increase throughput, while decreasing operating costs.

Performance

Available in 30 lb, 35 lb, 50 lb, 55 lb, 75 lb, 120 lb, 170 lb and 200 lb capacities, there's a tumble dryer to meet the needs of any on-premises laundry.

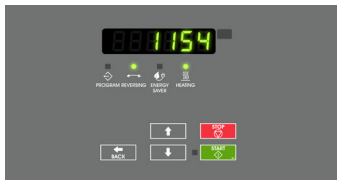

Galaxy™

The Galaxy Control offers the flexibility of 30 programmable cycles combined with the accuracy of our moisture-sensing technology saving time and energy increasing the life of your linens, saving time and energy.



Dual Digital

With features including one-touch cycle repeat, automatic extended tumble and a large digital countdown display, it's simple to set your drying time, temperature and cool down with the Dual Digital Control.

* Not all models are available in all markets. In order to highlight key details, machine images do not adhere to a standard scale.

On-Premises 30-lb Tumble Dryer Specifications

MODEL		HT030	
CONTROL OPTION		Galaxy, Dual Digital	
CAPACITY - lb (kg)		30 (13)	
OVERALL WIDTH - in (mm)		27.9 (710)	
OVERALL DEPTH - in (mm)		45.5 (1155)	
OVERALL HEIGHT - in (mm)		63.9 (1625)	
CYLINDER DIAMETER - in (mm)		26.5 (673)	
CYLINDER DEPTH - in (mm)		30.0 (762)	
CYLINDER VOLUME - cu. ft. (liters)		9.6 (270)	
REVERSING CYLINDER		Option	
DOOR OPENING SIZE - in (mm)		22.7 (577)	
HEAT INPUT POWER	Gas Models - Per Pocket	73,000 Btu/hr	
	Electric Models	21kW	
GAS CONNECTIONS* - in (npt)		0.5	
AIR OUTLET - in (mm)		6 (152)	
MOTOR - hp	Fan	0.5	
	Cylinder	0.3	
AIRFLOW - cfm		500	
ELECTRICAL SPECS - amps	Gas		
	B	100-120V/50/60/1	10
	X	200-240V/50/60/1/3	6
	N	440-480V/50/60/3	3
	Electric		
	D	200-208V/50/60/1	104
	E	230-240V/50/60/1	90
	F	200-208V/50/60/3	61
	G	230-240V/50/60/3	52
	K	440V/50/60/3	29
L	460-480V/50/60/3	27	
SHIPPING DIMENSIONS APPROX. - in (mm)	Width	30.0 (762)	
	Depth	49.0 (1245)	
	Height	67.6 (1717)	
NET WEIGHT - lb (kg)	Gas	320 (145)	
	Electric	330 (150)	
SHIPPING WEIGHT - lb (kg)	Gas	340 (155)	
	Electric	350 (160)	
AGENCY APPROVALS		CSA	

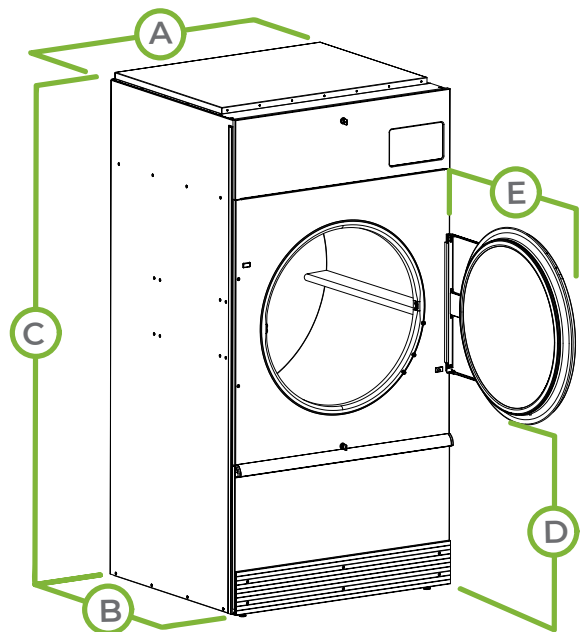

MODEL	HT030
A. OVERALL WIDTH - in (mm)	27.9 (710)
B. OVERALL DEPTH - in (mm)	45.5 (1155)
C. OVERALL HEIGHT - in (mm)	63.9 (1625)
D. DOOR BOTTOM TO FLOOR - in (mm)	27.5 (700)
E. DOOR SWING - in (mm)	26.3 (670)

* LP gas available for 50,75 lb capacities only. Field conversion kits available for other capacities.

Tumble dryer models are made to suit a variety of electrical service characteristics. See your Huebsch distributor for specifications. For further details on installation, refer to Installation, Operation and Maintenance instructions supplied with the tumble dryer. Amperage ratings available in Installation Manual.

For the most accurate information, the installation guide should be used for all design and construction purposes. Due to continuous product improvements, design and specifications subject to change without notice. The quality management systems at Alliance Laundry Systems are registered to ISO 9001.